

SYNCHRONOUS RELUCTANCE MAGNET ASSISTED NEMA MOTOR
WITH EMBEDDED AC-LINK VARIABLE SPEED DRIVE

25 / 15 HP, 1800 / 1200 RPM, 460V, 3PH, 60HZ, 284/6T, TEFC, F3
Model: EMDX025H18EXS3ABAA

NAMEPLATE

OUTPUT	SPEED	FRAME	VOLTAGE	FREQUENCY	PHASE	RATED CURRENT
25 / 15 HP	1800 / 1200 RPM	284/6T	460 V	60 Hz	3	25.1 / 15.6 A
ENCLOSURE	DUTY RATING	SERVICE FACTOR	INSULATION CLASS	MOTOR EFF. (%)	PDS EFF. (%) ¹	POWER FACTOR
TEFC	CONT.	1.0	H	94.8% / 95.7%	91.9% / 92.5%	0.99 / 0.98
MAXIMUM SPEED	MINIMUM SPEED	CONSTANT POWER	VARIABLE TORQUE	EFFICIENCY CLASS	AREA CLASSIFICATION	
2500 RPM	180 RPM	1800 to 2500 RPM	180 to 1800 RPM	IE4 / IES2	Class I Division II Groups A,B,C,D T4	

CALCULATED PERFORMANCE @ 460V 3PH 60HZ

Rated Load:	25.0 HP	RATED LOAD	100%	75%	50%	25%
Rated Speed:	1770 RPM	PDS EFF. (%)¹	91.9%	91.0%	89.2%	82.1%
Rated Current:	25.1 A	POWER FACTOR	0.99	0.99	0.98	0.94
Rated Torque:	74.2 ft-lbs	CURRENT	25.1 A	17.7 A	12.1 A	6.8 A
Number of Poles:	8	NOISE LEVEL:		RATED ENVIRONMENT		
Output Frequency:	118.0 Hz	Noise Level:	80 dB(A)	Amb. Temperature:	-25 to 40°C (50°C with de-rate)	
		Measured at 1m with tolerance of +3 dB(A)		Max Elevation:	1000 m (2000 m with de-rate)	

BEARINGS

Bearing Type NDE:	6310C3
Bearing Type DE:	6310C3
Lubricant Type:	Mobil Polyrex EM
Lubricant Interval:	4500 Hours
Bearing Seal DE:	Inpro/Bronze
Bearing Seal NDE:	Sealed

INSTALLATION

Terminal Box Mounting :	F3
Motor Lead Termination:	Ring Terminals
Approximate Weight: ²	507 lbs
Overall 'C' Length:	31.67 in.
Shaft Rotation	Both (CW and CCW)
Shaft Diameter:	1.625 in.

AGENCY APPROVALS

Conforms to UL STD 121201 (Full Assembly)
Certified to CSA STD C22.2 No 213 (Full Assembly)
Conforms to UL STD 61800-5-1 (Converter)
Certified to CSA STD C22.2 No. 274 (Converter)
UR - UL Recognized (Motor)

THERMAL PROTECTION

Overload Protection:	Integral - 120% @ 60s / 150% @ 3s
Thermal Device - Winding:	2xKTY84 (1 Primary / 1 Back-Up)
Thermal Device - Converter:	Integral Temperature Monitoring
Thermal Device NDE Bearing:	None
Thermal Device DE Bearing:	None

GENERAL SPECIFICATIONS

Frame Material:	Cast Iron	Input Voltage:	460V +10% / -5%
Terminal Box Material:	Aluminum	Voltage Imbalance:	±3% phase to phase
Motor IP Rating:	TEFC - IP55	Input Frequency:	47-63 Hz
Terminal Box IP Rating:	IP66	Harmonic Current Distortion:	THDi < 5% @ 100% Load
Starting Method:	Integral Soft Start/Stop	RFI/EMI Filter:	EN55011 (CISPER 11): Class A (industrial): C3
Anti-condensation:	Integral w/ 460V mains	Safety Integrity Level:	IEC61508 SIL2, ISO13849-1 Category 3PL d
Speed Feedback Device:	Sensorless	Cooling Method:	IC411-TEFC
Keypad Interface:	External	Back EMF: ⁴	8V/100RPM

NOTES

1. PDS Eff. - Power Drive System Efficiency is the combined motor and converter efficiency as defined by IEC 61800-9
2. Approximate weight subject to change after manufacturing
3. Values are preliminary averages subject to tolerances.
4. Motor contains permeant ferrite magnets. When shaft is rotated voltage can be generated at the motor terminals.

PROJECT NAME

APPLICATION / TAG NO.

CUSTOMER	SALES ORDER	PREPARED	DOCUMENT NO.	REV.
		K. Khan	Data Sheet	1.0
CUSTOMER PO	PROJECT NO.	APPROVED	DATE ISSUED	PAGE
		D. Williams	3/1/2026	1 OF 9

**SYNCHRONOUS RELUCTANCE MAGNET ASSISTED NEMA MOTOR
WITH EMBEDDED AC-LINK VARIABLE SPEED DRIVE**

25 / 15 HP, 1800 / 1200 RPM, 460V, 3PH, 60HZ, 284/6T, TEFC, F3

Model: EMDX025H18EXS3ABAA

VARIABLE SPEED OPERATION CURVE

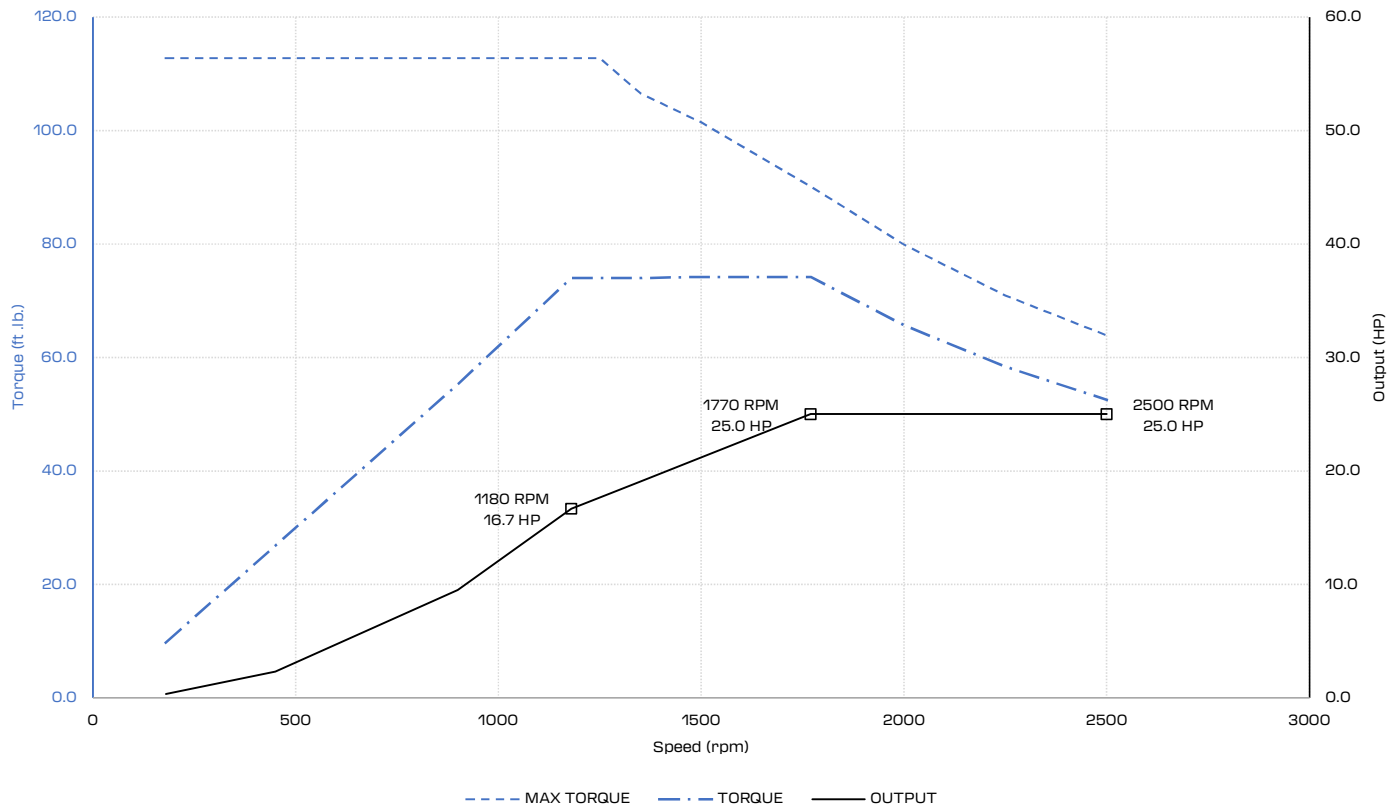

CALCULATED PERFORMANCE @ 460V 3PH 60HZ

	SPEED RPM	MOTOR FREQ. HZ	MAX. TORQUE FT-LBS	TORQUE FT-LBS	OUTPUT HP
Rated Speed:	1770 RPM				
Rated Current:	25.1 A				
Rated Torque:	74.2 ft-lbs				
Number of Poles:	8				
Output Frequency:	118.0 Hz				
Service Factor:	1.0				
Insulation Class:	H				
Duty Rating:	CONT.				
Amb. Temperature:	-25 to 40°C				
Max Elevation:	1000 m				
	180	12.0	112.8	9.7	0.3
	450	30.0	112.8	26.8	2.3
	900	60.0	112.8	55.2	9.5
	1180	78.7	112.8	74.0	16.7
	1250	83.3	112.8	74.0	17.7
	1350	90.0	106.5	74.0	19.1
	1500	100.0	101.4	74.2	21.2
	1770	118.0	90.2	74.2	25.0
	2000	133.3	79.9	65.7	25.0
	2250	150.0	70.9	58.4	25.0
	2500	166.7	63.9	52.5	25.0

NOTES

1. Values are averages subject to tolerances.
2. Max Torque shown subject to overload and/or over temperature trips

PROJECT NAME		APPLICATION / TAG NO.		
CUSTOMER	SALES ORDER	PREPARED K. Khan	DOCUMENT NO. Data Sheet	REV. 1.0
CUSTOMER PO	PROJECT NO.	APPROVED D. Williams	DATE ISSUED 3/1/2026	PAGE 2 OF 9

SYNCHRONOUS RELUCTANCE MAGNET ASSISTED NEMA MOTOR
WITH EMBEDDED AC-LINK VARIABLE SPEED DRIVE

25 / 15 HP, 1800 / 1200 RPM, 460V, 3PH, 60HZ, 284/6T, TEFC, F3
Model: EMDX025H18EXS3ABAA

CURRENT OVERLOAD CURVE

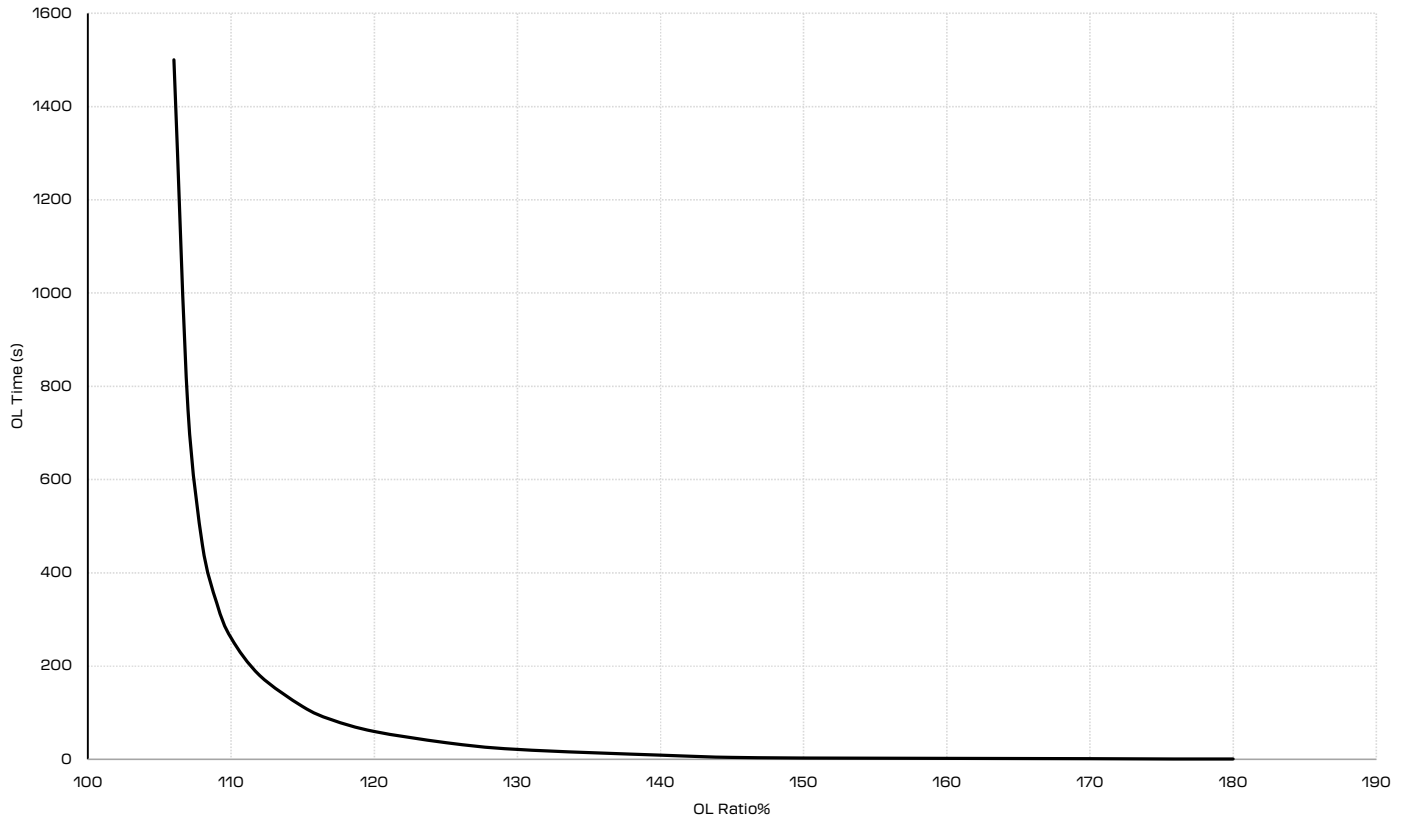

Overload Ratio ¹	OL Time (s)	Recover Time (s)
106%	1500	309
110%	260	273
120%	60	198
140%	9	75
150%	3	43
170%	1.2	40
180%	1	40

NOTES

- Ratio is based on the output current to the motor.
- Overload protection is integral to the VIDAR motor. Separate motor overload protection is not required.

PROJECT NAME		APPLICATION / TAG NO.		
CUSTOMER	SALES ORDER	PREPARED K. Khan	DOCUMENT NO. Data Sheet	REV. 1.0
CUSTOMER PO	PROJECT NO.	APPROVED D. Williams	DATE ISSUED 3/1/2026	PAGE 3 OF 9

SYNCHRONOUS RELUCTANCE MAGNET ASSISTED NEMA MOTOR
WITH EMBEDDED AC-LINK VARIABLE SPEED DRIVE

25 / 15 HP, 1800 / 1200 RPM, 460V, 3PH, 60HZ, 284/6T, TEFC, F3

Model: EMDX025H18EXS3ABAA

GENERAL ARRANGEMENT DRAWING

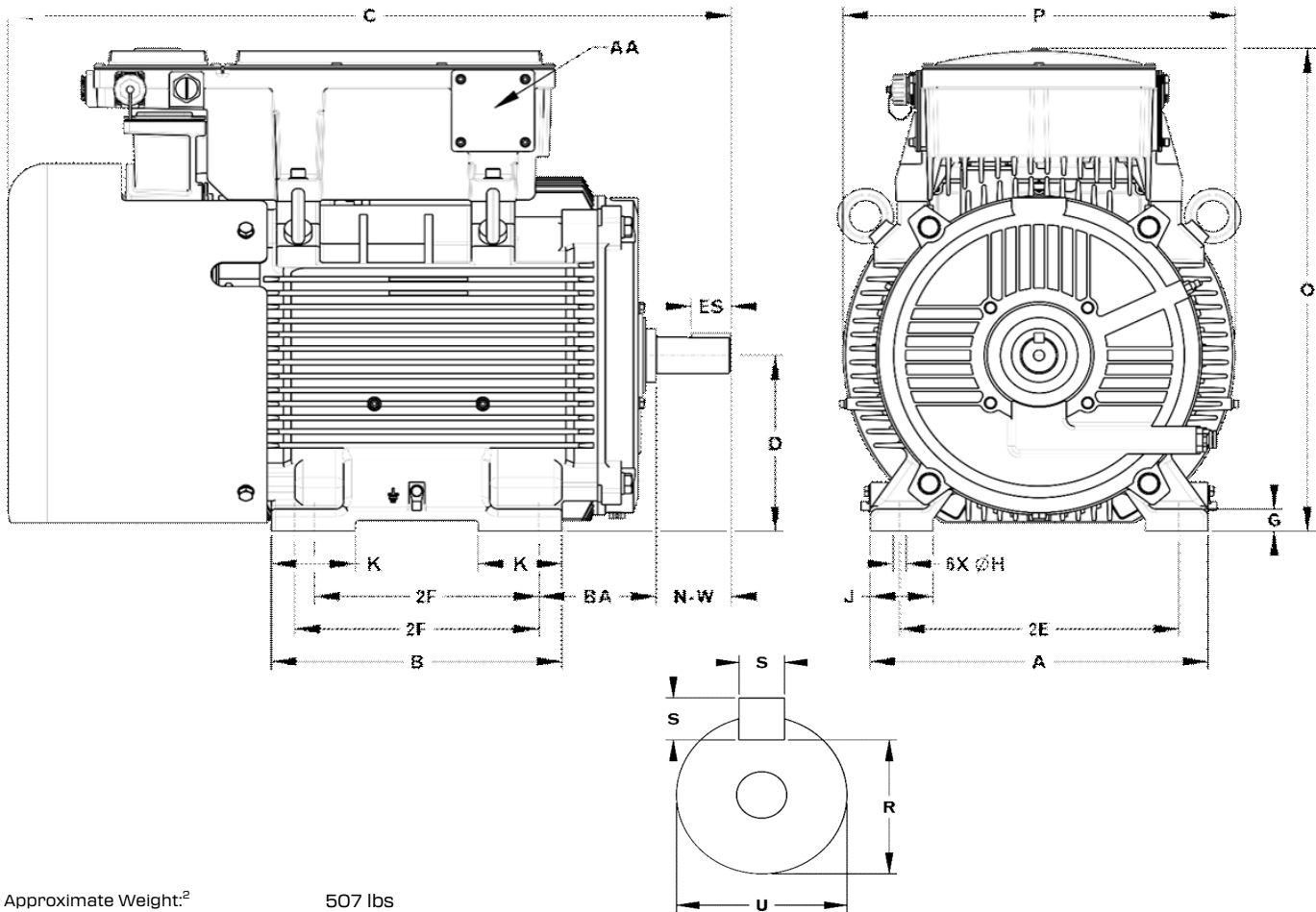

Approximate Weight:² 507 lbs
Terminal Box Mounting³ F3

CRITICAL DIMENSIONS (IN.)

FRAME	2E	2F	H	BA	A	B
284/6T	11.00	9.50 \ 11.00	0.53	4.75	12.76	12.60
	C	D	G	J	O	K
	31.67	7.00	0.74	2.36	20.17	3.74
	P	S	R	ES	N-W	U
	15.59	0.50	1.591	3.28	4.63	1.875
AA	AB	HB	AJ	AK	BF	

NOTES

1. Shaft key provided with motor.
2. Approximate weight subject to change after manufacturing.
3. Tapped bolt holes given in Unified National Coarse

PROJECT NAME		APPLICATION / TAG NO.			
CUSTOMER	SALES ORDER	PREPARED K. Khan	DOCUMENT NO. Data Sheet	REV. 1.0	
CUSTOMER PO	PROJECT NO.	APPROVED D. Williams	DATE ISSUED 3/1/2026	PAGE 4 OF 9	

SYNCHRONOUS RELUCTANCE MAGNET ASSISTED NEMA MOTOR
WITH EMBEDDED AC-LINK VARIABLE SPEED DRIVE

25 / 15 HP, 1800 / 1200 RPM, 460V, 3PH, 60HZ, 284/6T, TEFC, F3
Model: EMDX025H18XS3ABAA

MOTOR WIRING DIAGRAM

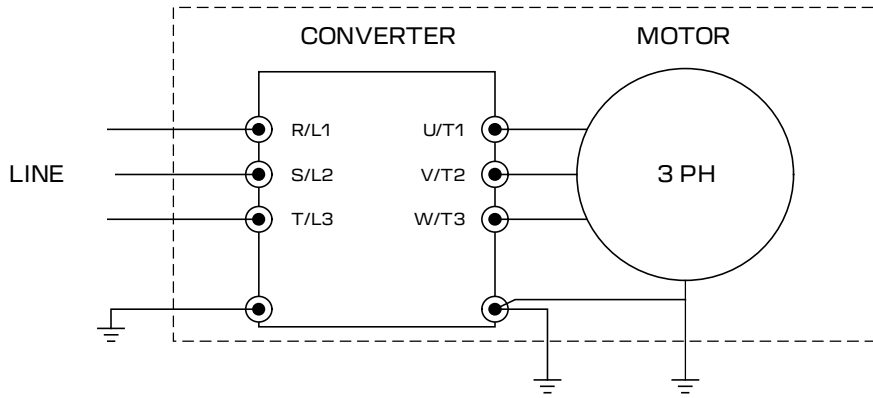

INPUT POWER TERMINAL BOX

INPUT POWER TERMINALS (R/L1, 2/L2, T/L3)

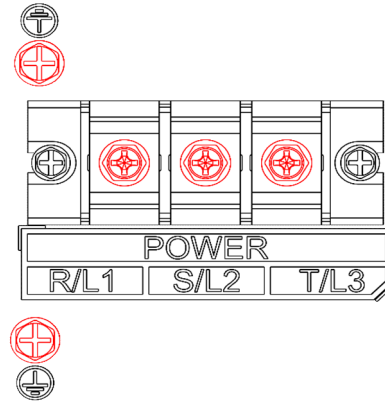
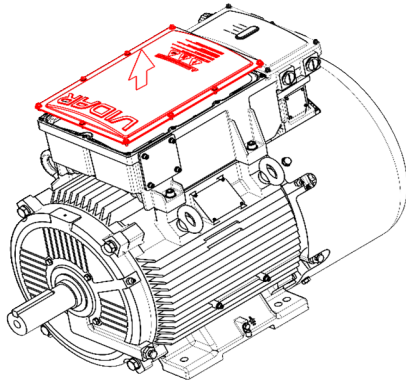

TERMINAL	CONDUIT ENTRY	MAX. WIRE GAUGE	MIN. WIRE GAUGE	TORQUE SPEC. ± 10%
Main Circuit Terminal	2 x 1.50 in. NPT	6 AWG	8 AWG	32.6 lb-in
Ground Terminal		8 AWG	8 AWG	21.7 lb-in

NOTES

1. Motor can be either wye or delta connected.
2. For an ungrounded/floating delta or high resistance ground wye connection refer to the user manual to disconnect the EMI filter.
3. The motor will rotate counterclockwise (viewed from the shaft end) in the forward direction. To change the motor direction refer to the user manual to reverse the direction through the keypad or to permanently reverse the forward direction, switch two of the motor phases U/T1, V/T2, W/T3.

PROJECT NAME

APPLICATION / TAG NO.

CUSTOMER

SALES ORDER

PREPARED

DOCUMENT NO.

REV.

K. Khan

Data Sheet

1.0

CUSTOMER PO

PROJECT NO.

APPROVED

DATE ISSUED

PAGE

D. Williams

3/1/2026

5 OF 9

SYNCHRONOUS RELUCTANCE MAGNET ASSISTED NEMA MOTOR
WITH EMBEDDED AC-LINK VARIABLE SPEED DRIVE

25 / 15 HP, 1800 / 1200 RPM, 460V, 3PH, 60HZ, 284/6T, TEFC, F3

Model: EMDX025H18EXS3ABAA

APPLICATION CONTROL WIRING INSTALLATION

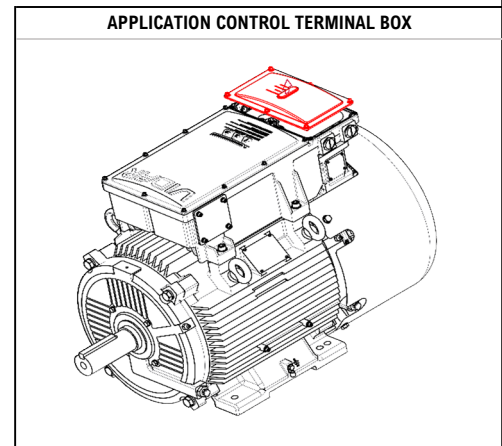
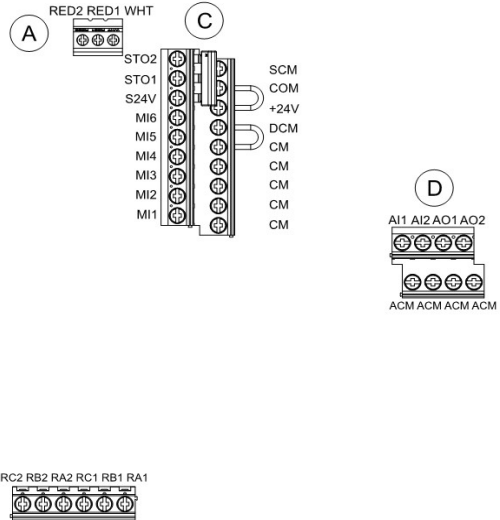
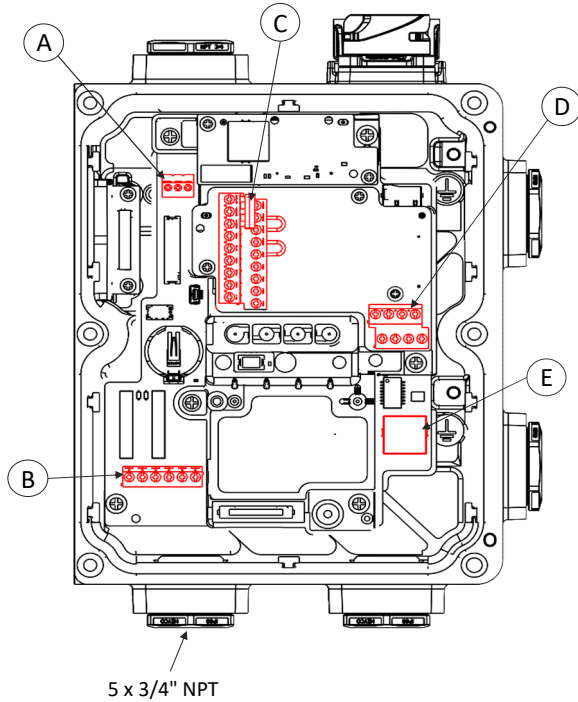

CONTROL WIRE SPECIFICATIONS

TERMINAL NAME	GROUP	CONDUCTOR	STIPPING LENGTH	MAX. WIRE GAUGE	MIN. WIRE GAUGE	TORQUE SPEC. ± 10%
RTD Terminal	A	Solid / Strand	0.25 in.	20 AWG	24 AWG	1.8 lb.-in.
Relay Terminals	B	Solid / Strand	0.25 in.	16 AWG	24 AWG	4.0 lb.-in.
Digital Terminals	C	Solid / Strand	0.25 in.	18 AWG	24 AWG	4.3 lb.-in.
Analog Terminals	D	Solid / Strand	0.25 in.	18 AWG	24 AWG	4.3 lb.-in.
Ethernet IP / TCP	E	RJ45 CAT 6				

NOTES

PROJECT NAME		APPLICATION / TAG NO.			
CUSTOMER	SALES ORDER	PREPARED	DOCUMENT NO.	REV.	
		K. Khan	Data Sheet	1.0	
CUSTOMER PO	PROJECT NO.	APPROVED	DATE ISSUED	PAGE	
		D. Williams	3/1/2026	6 OF 9	

**SYNCHRONOUS RELUCTANCE MAGNET ASSISTED NEMA MOTOR
WITH EMBEDDED AC-LINK VARIABLE SPEED DRIVE**

25 / 15 HP, 1800 / 1200 RPM, 460V, 3PH, 60HZ, 284/6T, TEFC, F3

Model: EMDX025H18EXS3ABAA

APPLICATION CONTROL WIRING DIAGRAM

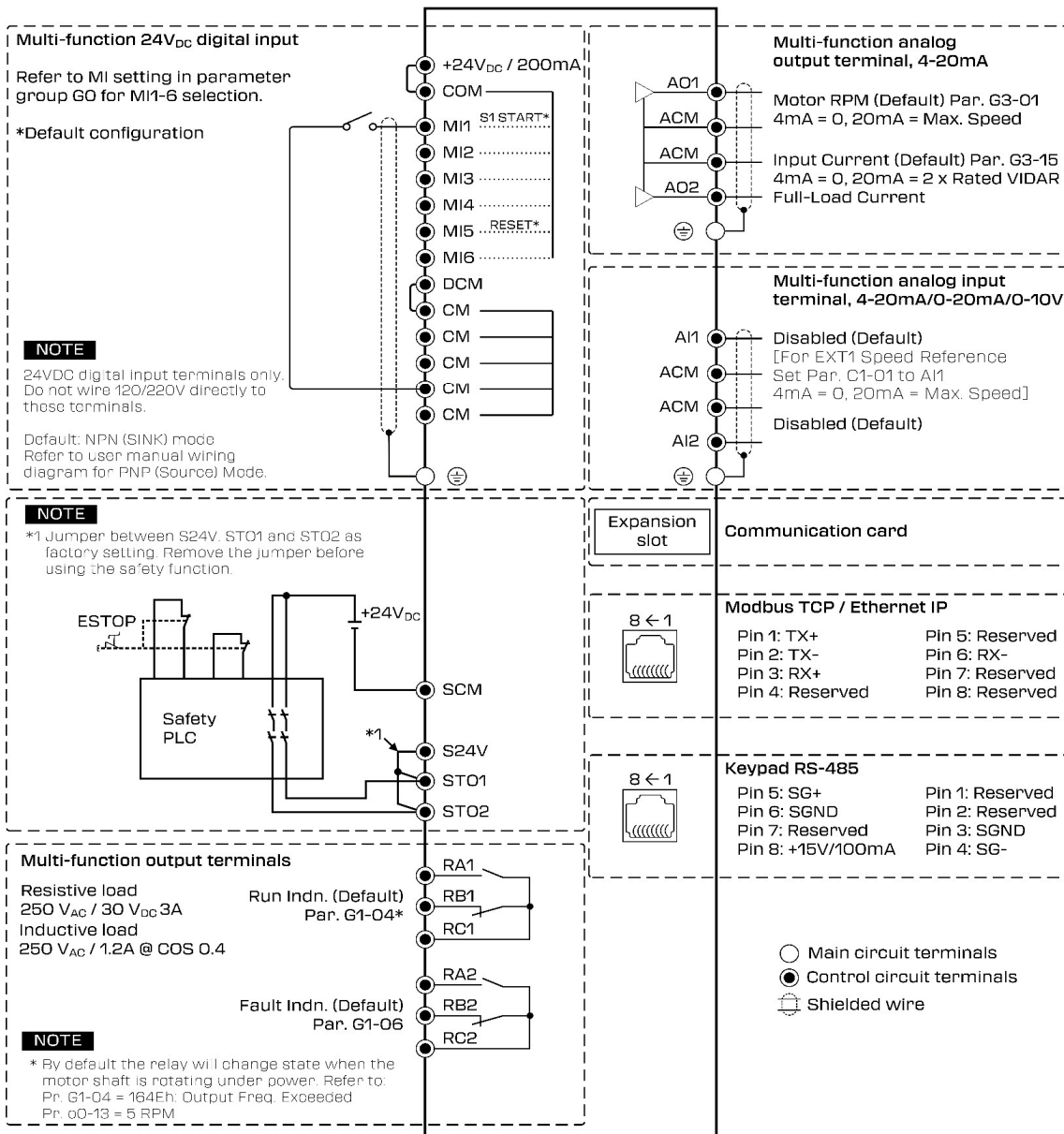

NOTES

PROJECT NAME		APPLICATION / TAG NO.		
CUSTOMER	SALES ORDER	PREPARED	DOCUMENT NO.	REV.
CUSTOMER PO	PROJECT NO.	K. Khan	Data Sheet	1.0
		APPROVED	DATE ISSUED	PAGE
		D. Williams	3/1/2026	7 OF 9

**SYNCHRONOUS RELUCTANCE MAGNET ASSISTED NEMA MOTOR
WITH EMBEDDED AC-LINK VARIABLE SPEED DRIVE**

25 / 15 HP, 1800 / 1200 RPM, 460V, 3PH, 60HZ, 284/6T, TEFC, F3

Model: EMDX025H18EXS3ABAA

CONTROL WIRING SPECIFICATION

Terminals	Terminal Function	Description
+24V	+24V power supply	+24 V _{DC} ± 10% 200 mA
COM	Digital control signal common (Sink)	Multi-function input common terminal
MI1 M6	Multi-function 24VDC Digital Input Selection 1-6	MI1-MI6 support three-wire / two-wire control Refer to the MI setting in Parameter Group G0 for MI1-MI6 function selection. Source Mode: ON: activation voltage ≥ 15 VDC OFF: cut-off voltage ≤ 5 VDC Sink Mode: ON: activation voltage ≤ 9 VDC OFF: cut-off voltage ≥ 19 VDC
DCM	Digital signal common	Digital signal common
CM	Extended digital signal common	Extended digital signal common
RA1	Multi-function relay output 1 (N.O.) a	To output various kinds of monitoring signals such as motor drive in operation, frequency reached, and overload indication. Resistive Load 3 A (N.O.) / 3 A (N.C.) 250 VAC 3 A (N.O.) / 3 A (N.C.) 30 VDC Inductive Load (COS 0.4) 1.2 A (N.O.) / 1.2 A (N.C.) 250 VAC 1.2 A (N.O.) / 1.2 A (N.C.) 30 VDC
RB1	Multi-function relay output 1 (N.C.) b	
RC1	Multi-function relay common (Relay)	
RA2	Multi-function relay output 2 (N.O.) a	
RB2	Multi-function relay output 2 (N.C.) b	
RC2	Multi-function relay common (Relay)	
AI1 AI2	Multi-function analog input	The two analog input formats both support 0-20 mA / 4-20 mA (default) and 0-10 V Voltage type input resistance: 20 kΩ Current type input resistance: 250 Ω
AO1 AO2	Multi-function analog output	The two analog outputs both support 0-+10V / 0-20 mA / 4-20 mA (default) Under voltage mode (0-10 V), the max. output current is 2 mA Voltage type load limit: > 5 kΩ Current type load limit: < 500 Ω
ACM	Analog Signal Common	Analog signal common terminal
STO1	Default short circuit of STO1-STO2-S24V (disable STO function). Only provide Source trigger mode. Built-in STO/SIL2 according to IEC61800-5-2, EN 61508 SIL2/ EN ISO 13849-1 PLd STO1-SCM; STO2-SCM ON: voltage ≥ 15 VDC STO1-SCM; STO2-SCM OFF: voltage ≤ 5 VDC S24V-SCM only use for STO1 and STO2 circuit	
STO2		
S24V		
SCM		
RJ45_KPD	RJ45 keypad connection	PIN1, 2, 7: Reserve PIN3, 6: SGND PIN4: SG- PIN5: SG+ PIN8: +15V/100 mA
RJ45_EIP	PJ45 Ethernet IP / Modbus TCP connection	PIN1: TX+ PIN2: TX- PIN3: RX+ PIN6: RX- PIN4, 5, 7, 8: Reserved
WHT	RTD temperature detector - white wire	Only apply to three-wire RTD temperature detector
RED1	RTD temperature detector - red wire	
RED2	RTD temperature detector - red wire	

NOTES

PROJECT NAME		APPLICATION / TAG NO.		
CUSTOMER	SALES ORDER	PREPARED	DOCUMENT NO.	REV.
CUSTOMER PO	PROJECT NO.	K. Khan	Data Sheet	1.0
		APPROVED	DATE ISSUED	PAGE
		D. Williams	3/1/2026	8 OF 9

SYNCHRONOUS RELUCTANCE MAGNET ASSISTED NEMA MOTOR
WITH EMBEDDED AC-LINK VARIABLE SPEED DRIVE

25 / 15 HP, 1800 / 1200 RPM, 460V, 3PH, 60HZ, 284/6T, TEFC, F3

Model: EMDX025H18EXS3ABAA

UNIVERSAL KEYPAD INTERFACE

EMD-KT-KP-CC01

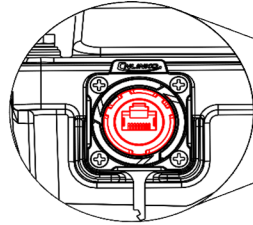
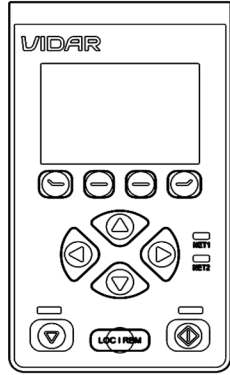

External keypad RJ45 Connector

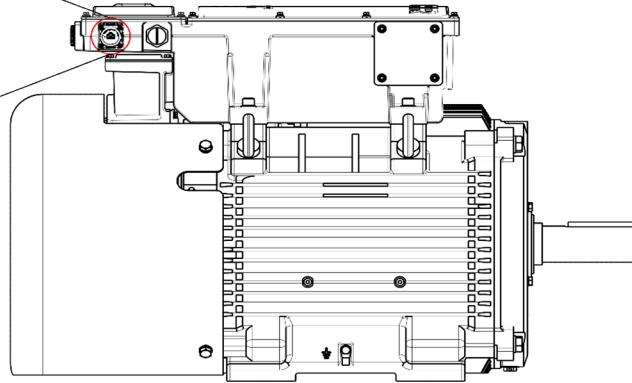

Communication Protocol: RS-485, RJ45 (socket)
Standard cable length: 5M / 16FT
Area Classification: Class I Division II Groups A,B,C,D T4

KEYPAD CONNECTION INSTRUCTIONS

STEP 1
Remove waterproof cover

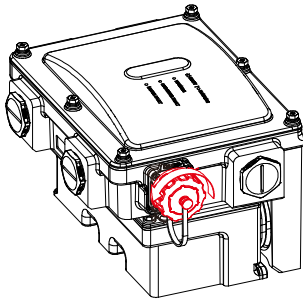

STEP 2
Insert the RJ45 waterproof keypad connector

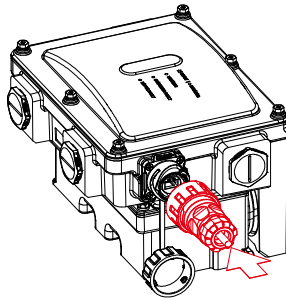

STEP 3
Rotate keypad connector clockwise to enable keypad

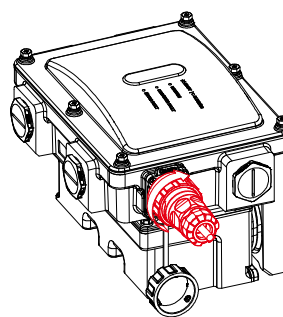

STEP 4
Reverse steps to remove and replace waterproof cover

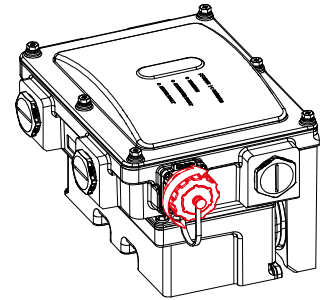

NOTES

1. Universal external keypad sold separately.
2. For keypad remote mounting refer to user's manual.

PROJECT NAME

APPLICATION / TAG NO.

CUSTOMER

SALES ORDER

PREPARED

DOCUMENT NO.

REV.

CUSTOMER PO

PROJECT NO.

APPROVED

DATE ISSUED

PAGE

K. Khan

Data Sheet

1.0

D. Williams

3/1/2026

9 OF 9